

# LCI-750-C2

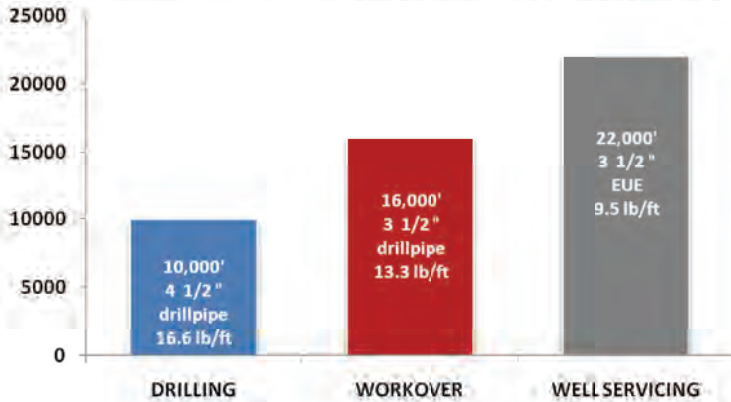

## Drawworks Model 750/4212-42

### Main Drum

- > Demountable, forged steel brake rims are 42" diameter x 12" wide
- > Brakes are cooled by circulating water
- > Drum shaft diameter is 6 1/2"
- > Single line pull is 45,000 lbs.
- > Outboard Eaton (Fawick) clutch
- > Parmac Model 202 Auxiliary brake standard

### Sandline Drum

- > Demountable, forged steel brake rims are 42" diameter x 8" wide
- > Water splash brake cooling
- > Wireline capacity per AOSC approved formula:
  - 16,500' of 9/16"
  - 13,400' of 5/8"
- > Outboard Eaton (Fawick) Clutch

### Drawworks Options

- > LEBUS grooving on main drum - 1 1/8" diameter
- > Rotary drive-torque shaft from right angle box
- > Crown block saver
- > Disc brake in lieu of Parmac Auxiliary brake

### Mast Model 116 x 365 Twin Box (per API 4F)

- > Twin box leg fixed base design allows fast positioning of rig before mast is raised. Clear height is 116' below crown.
- > Static hook load capacity:
  - on 8 lines 350,000 lbs.
  - on 10 lines 365,000 lbs.
- > Crossover crown with 36" fast line sheave plus five 30" sheaves
- > All sheaves mounted on Timken double row bearings
- > Racking capacity 10,080' of 4 1/2" drill pipe
- > Two hydraulic raising rams and two hydraulic telescoping rams
- > 1 1/8" wire line standard

### Mast Options

- > Mast lights, standpipes, 24" sandline sheave

### Drive Train

- > Twin C15 or Ser 60 Detroit (475 to 540 HP Twin engine)
- > Allison CLT 6061 transmission (gear driven compound behind the transmissions)
- > Engine, transmission, and compound mounted in rubber above deck for easy access
- > Pressure lubricated combination right-angle box/drop box for drive to drawworks, rotary drive, and rear bogies

### Carrier – Seven Axle

- > Three front steering axles (rated at 22,000 lbs. each) have spring suspension
- > Rear tandem driving axles (rated at 50,000 lbs. total) have walking beam suspension
- > Third driver rear axle with air bag lift suspension is rated at 25,000 lbs. capacity
- > Pusher axles with air lift suspension is rated at 25,000 lbs. capacity

### Carrier Options

- > Two powered front steering axles are optional for use in rough or muddy terrain
- > Trailer models are available with either a single drop (gooseneck) or straight (rough terrain) design
- > Tool boxes, extra fuel tanks, spare tires, operator platforms can be supplied as needed

### Controls and Hydraulic System

- > The console panel for all leveling jacks, mast raising and extending cyl., engine, transmission, and main drum are located at one position for simple, quick rig-up. Operator's console can be provided movable to 12', 15', or 18' 6".
- > 50 gpm hydraulic pump for all rig hydraulics and tong operation
- > Filters provided on pressure and return lines

### Options

- > 70 gpm hydraulic pump
- > Hydraulic oil cooler for continuous use and hot climate applications
- > Single or dual 8,000 lbs. catline winch for safe, efficient lifting
- > Hydraulic catworks for precise control of make-up and break-out torques
- > Cold weather packages for -40° operation
- > Folding platforms off operator side of rig
- > Spare line spool
- > Mast lite package
- > Rig ramps and crossbase supports
- > Rig substructure - Hydraulic Telescopic type
- > Rotary chain case drive

## Hoist Performance

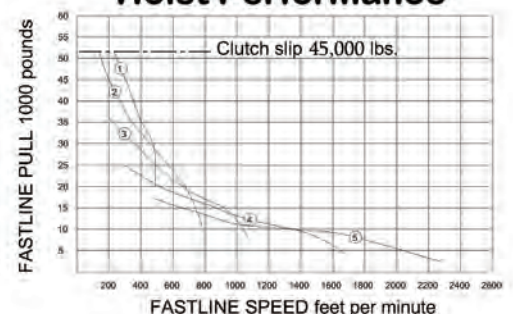



# LCI-750-C2



## Power Flow Diagram

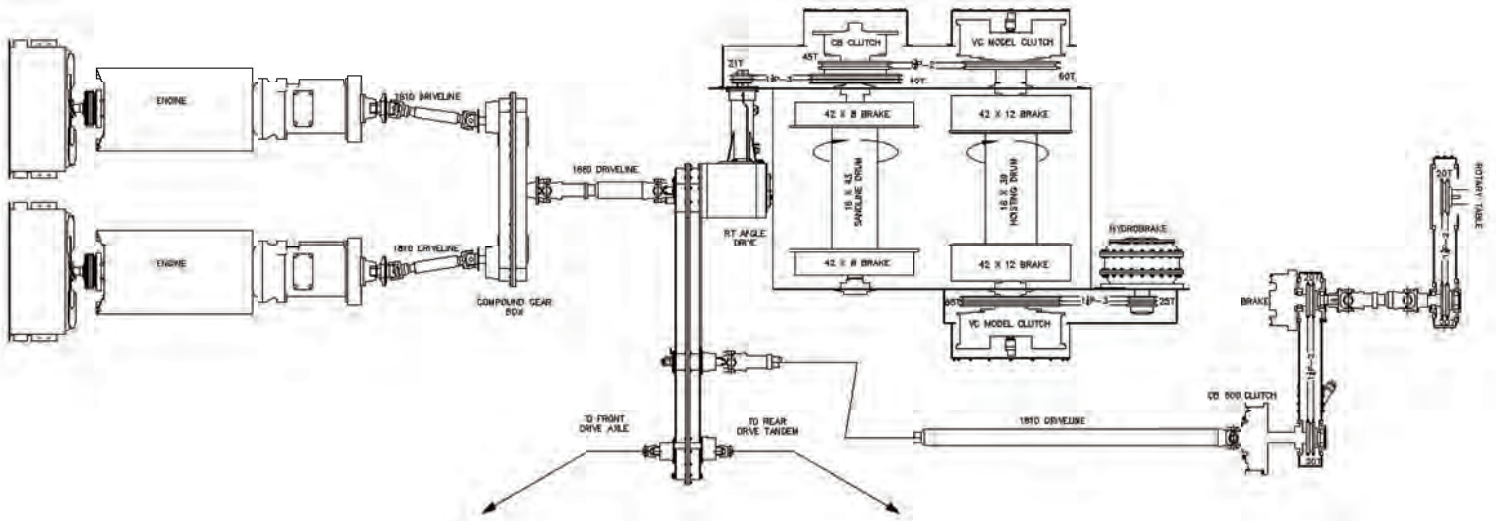

## Vehicle Layout

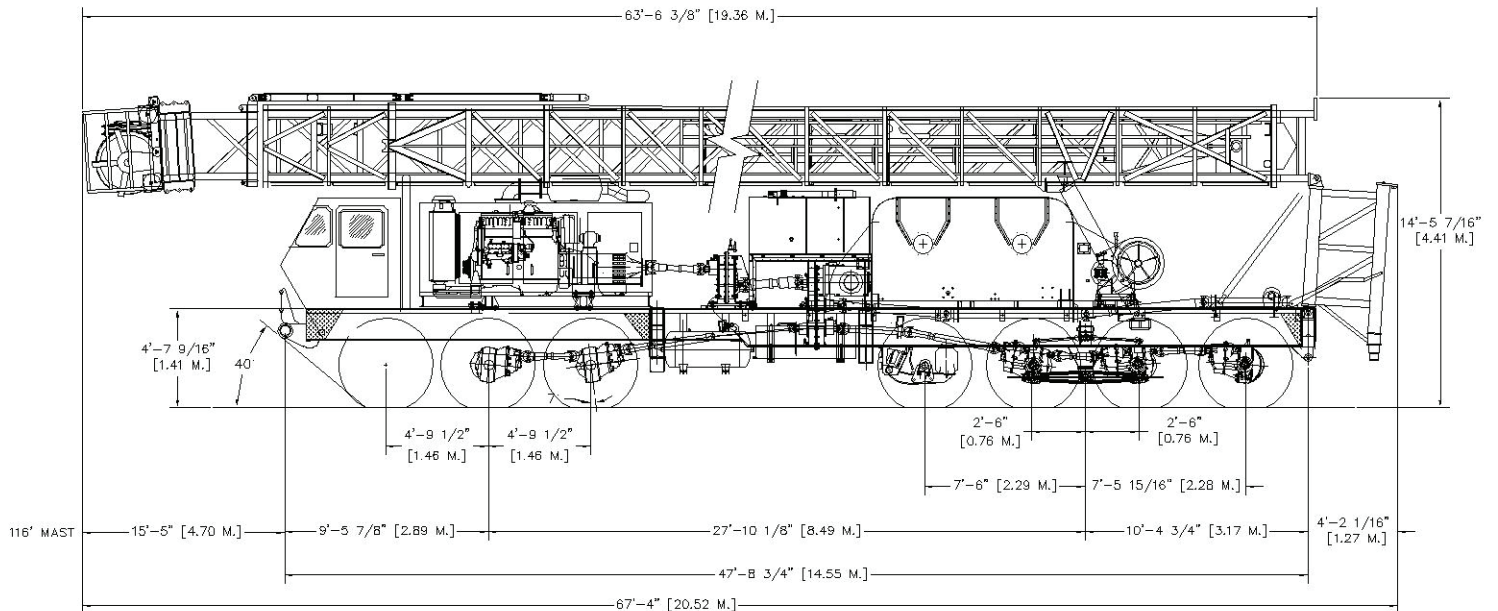



# LCI-750-C1

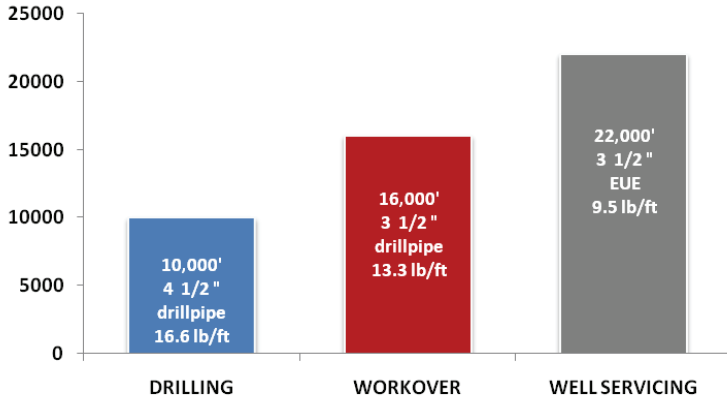

## Drawworks Model 750/4212-42

### Main Drum

- > Demountable, forged steel brake rims are 42" diameter x 12" wide
- > Brakes are cooled by circulating water
- > Drum shaft diameter is 6 1/2"
- > Single line pull is 45,000 lbs.
- > Outboard Eaton (Fawick) clutch
- > Parmac Model 202 Auxiliary brake standard

### Drawworks Options

- > LEBUS grooving on main drum - 1 1/8" diameter
- > Rotary drive-torque shaft from right angle box
- > Crown block saver
- > Disc brake in lieu of Parmac Auxiliary brake

### Mast Model 116 x 365 Twin Box (per API 4F)

- > Twin box leg fixed base design allows fast positioning of rig before mast is raised. Clear height is 116' below crown.
- > Static hook load capacity:
  - on 8 lines 350,000 lbs.
  - on 10 lines 365,000 lbs.
- > Crossover crown with 36" fast line sheave plus five 30" sheaves
- > All sheaves mounted on Timken double row bearings
- > Racking capacity 10,080' of 4 1/2" drill pipe
- > Two hydraulic raising rams and two hydraulic telescoping rams
- > 1 1/8" wire line standard

### Mast Options

- > Mast lights, standpipes

### Drive Train

- > Twin C15 or Ser 60 Detroit (475 to 540 HP Twin engine)
- > Allison CLT 6061 transmission
- > Optional 6610 Allison Series (gear driven compound behind the transmissions)
- > Engine, transmission, and compound mounted in rubber above deck for easy access
- > Pressure lubricated combination right-angle box/drop box for drive to drawworks, rotary drive, and rear bogies

### Carrier - Seven Axle

- > Three front steering axles (rated at 22,000 lbs. each) have spring suspension
- > Rear tandem driving axles (rated at 50,000 lbs. total) have walking beam suspension
- > Third driver rear axle with air bag lift suspension is rated at 25,000 lbs. capacity
- > Pusher axles with air lift suspension is rated at 25,000 lbs. capacity

### Carrier Options

- > Two powered front steering axles are optional for use in rough or muddy terrain
- > Trailer models are available with either a single drop (gooseneck) or straight (rough terrain) design
- > Tool boxes, extra fuel tanks, spare tires, operator platforms can be supplied as needed

### Controls and Hydraulic System

- > The console panel for all leveling jacks, mast raising and extending cyl., engine, transmission, and main drum are located at one position for simple, quick rig-up. Operator's console can be provided movable to 12', 15', or 18' 6".
- > 50 gpm hydraulic pump for all rig hydraulics and tong operation
- > Filters provided on pressure and return lines

### Options

- > 70 gpm hydraulic pump
- > Hydraulic oil cooler for continuous use and hot climate applications
- > Single or dual 8,000 lbs. or 12,000 lbs. catline winch for safe, efficient lifting
- > Hydraulic catworks for precise control of make-up and break-out torques
- > Cold weather packages for -40° operation
- > Folding platforms off operator side of rig
- > Spare line spool
- > Mast lite package
- > Rig ramps and crossbase supports
- > Rig substructure - Hydraulic Telescopic type
- > Rotary chain case drive

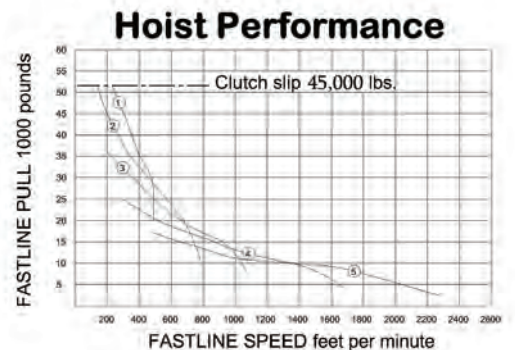

## Power Flow Diagram

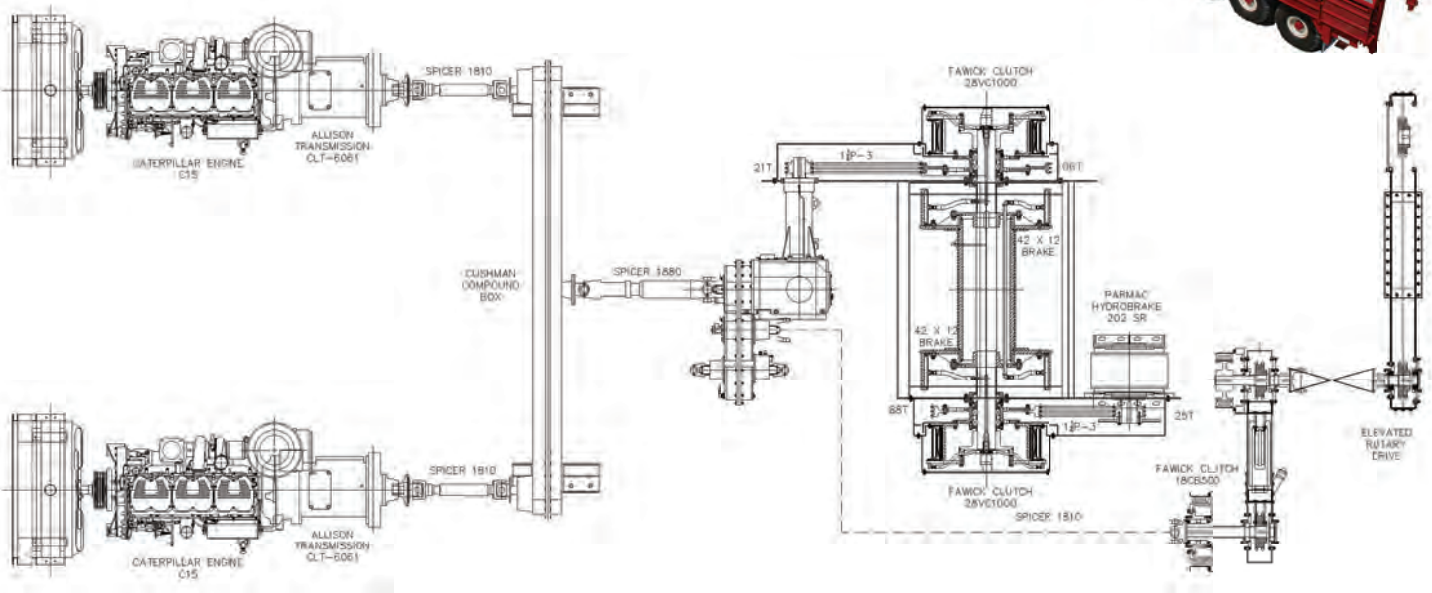

## Vehicle Layout

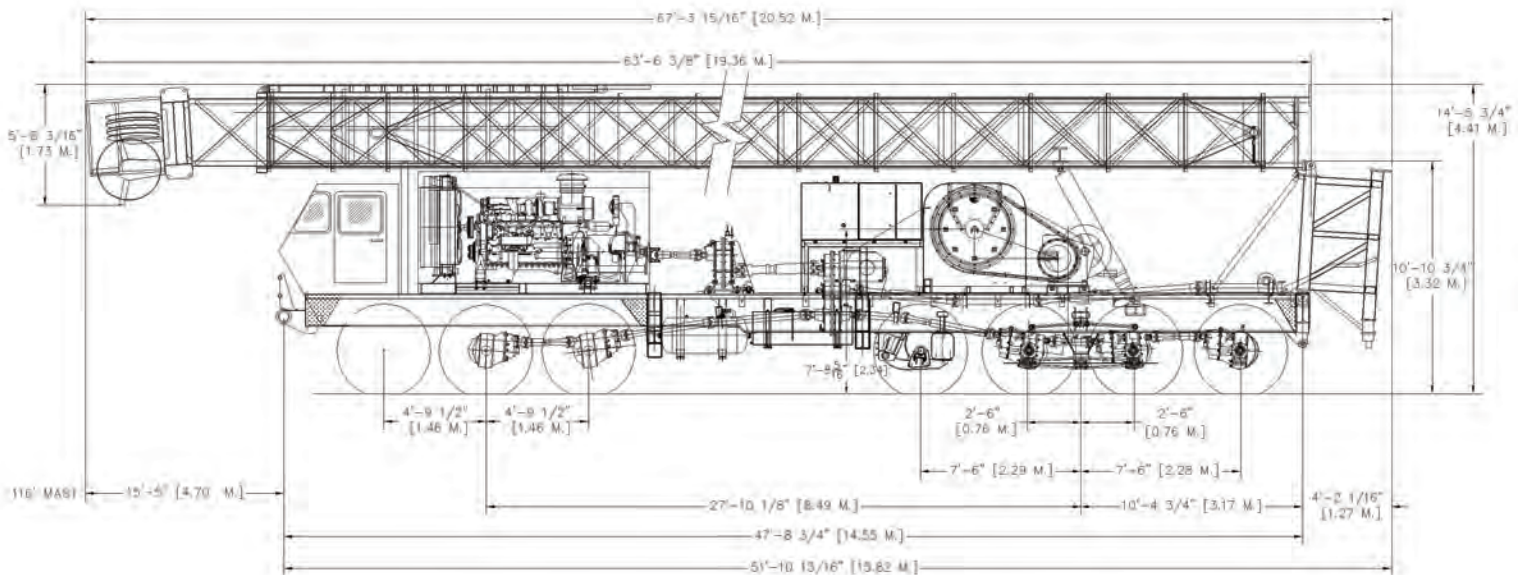



LOADCRAFT INDUSTRIES,

